

Stainless Steel Aluminium Honeycomb Composite Ceiling and Wall panel System

We specialize in premium custom metal solutions. Our stainless steel-faced aluminium honeycomb composite panels offer exceptional performance for ceilings and walls.

Aluminium Honeycomb Composite Panel:

A rigid, ultra-lightweight sandwich panel. It features a corrosion-resistant aluminium honeycomb core (aerospace-derived) bonded between two metal facings. Our ceiling systems use stainless steel as the top decorative facing.

Superior Flatness & Rigidity: The honeycomb core ensures exceptional dimensional stability and resistance to bending or sagging, crucial for large spans and flawless aesthetics.

Stainless Steel Honeycomb Ceiling System

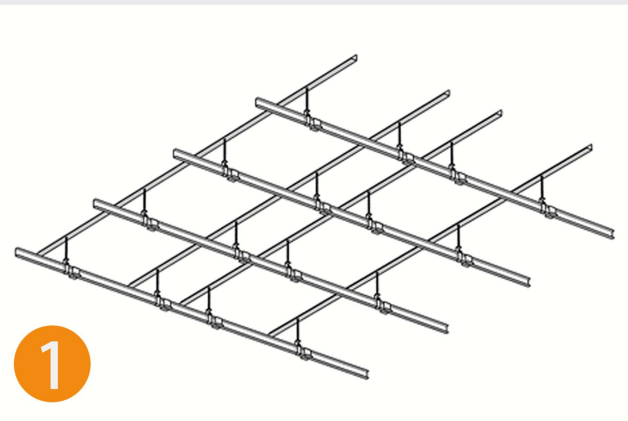
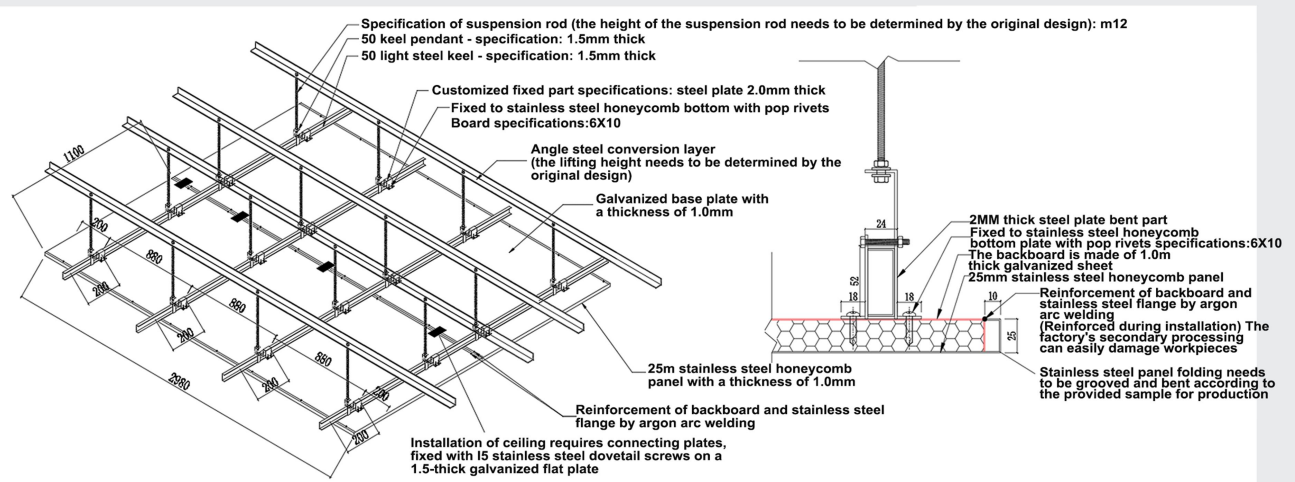

1
Install expansion screws, fix the screw rod and hook, install the main keel and triangular sub keel

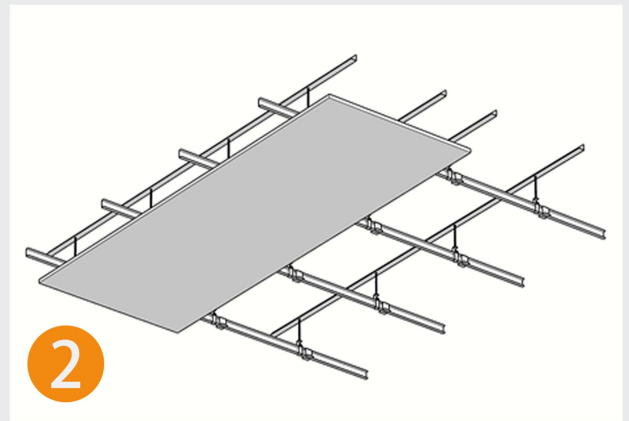

2
Install stainless steel honeycomb panels one by one along the triangular sub keel

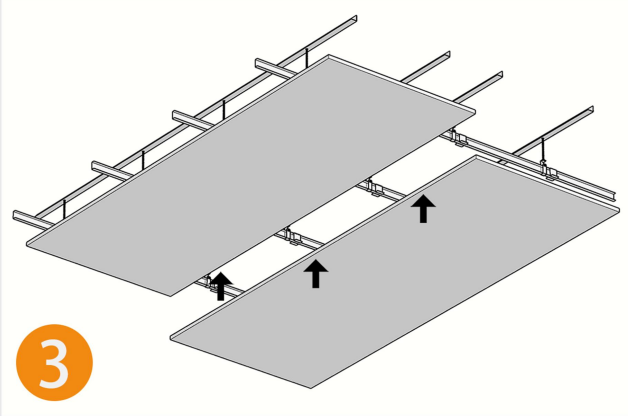

3
According to the second steps, and so on

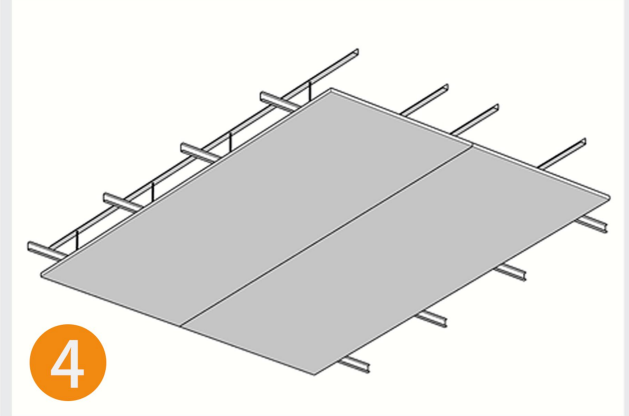

4
Finally complete the installation

Stainless Steel Composite Wall Panel System

